

DESIGN NOTES

Power over Ethernet Isolated Power Supply Delivers 11.5W at 90% Efficiency – Design Note 338

Jesus Rosales

When powering IP telephones, wireless access points, PDA charging stations and other PDs (Powered Devices) from an Ethernet cable, designers have at most 12.95W of available power per the IEEE 802[®].3af standard. Increased demands for power mandate a very efficient power converter especially for class 3 devices (consuming between 6.49W and 12.95W). The more power lost in the converter, the less power available for the PD.

The voltage available from the PSE (Power Sourcing Equipment) ranges from 44V to 57V, but PDs need to operate with as much as 20 Ω of series wire resistance. A PD can never draw more than 350mA or 12.95W continuously. With the maximum input current of 350mA_{RMS}, the input voltage can droop as much as 7V bringing the lower side of the input range to 37V. To avoid interfering with the classification signature impedance measurement, a PD must not draw significant current below 30V.

There are many topologies to choose from when designing an isolated DC/DC converter, but for PoE (Power over Ethernet) applications, the choices are few. When trying to maximize efficiency every milliwatt counts. MOSFET gate driving losses become significant so the fewer

switches to turn on and off the better. A push-pull converter could be used, but the additional complexity is not justified at this power level. A single transistor forward converter is another option, but requires an additional output inductor and rectifier. A flyback converter is the simplest choice. Flyback converters are thought to be less efficient than forward and push-pull converters, but that changes when the output is synchronously rectified (a MOSFET is used instead of a diode to rectify the output).

The LT[®]1725 switching regulator controller greatly simplifies the design of PoE supplies. The LT1725 is specifically designed for the isolated flyback topology and includes features that make it a good match for PoE supplies, including programmable input undervoltage lockout, hysteretic start-up and a patented feedback circuit that eliminates the need for an optocoupler while providing excellent output regulation¹.

In order to maximize power to the load, the converter chosen must have synchronous rectification. Diodes will

LT, LTC and LT are registered trademarks of Linear Technology Corporation. All other trademarks are the property of their respective owners.
¹U.S. Patent No. 05438499, 05305192, 0584163

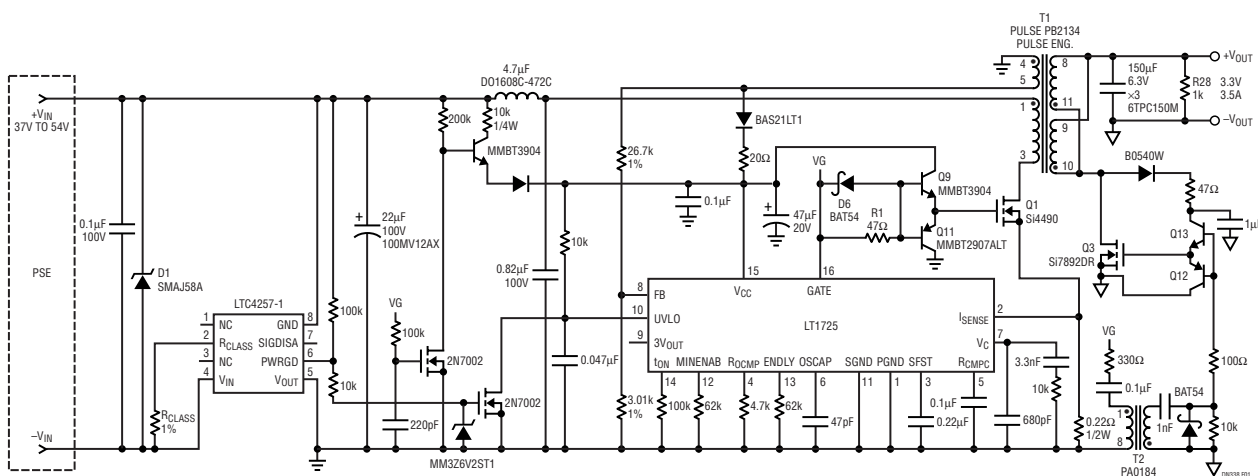

Figure 1. 36V-72V Input to 3.3V at 3.5A Output, Isolated Synchronous Flyback Converter

simply dissipate too much power. Figure 1 shows a schematic for an isolated synchronous flyback converter using the LT1725 that achieves efficiencies as high as 90% at 11.5W out. Figure 2 shows an efficiency curve for this synchronous converter and a second curve for the same converter with a 6CWQ06FN diode used in place of Q3 (making the converter nonsynchronous). While the synchronous converter needs a few extra components to control the rectifying MOSFET Q3, the resulting efficiency gain (approximately 10%) is significant. An additional benefit of the lower power dissipation with a MOSFET versus a diode is that a heat sink is no longer necessary, allowing for a dramatic reduction in board space. The other 5% efficiency gain comes from the elimination of preload. A synchronous converter does not need any preload to keep the output voltage in regulation while the nonsynchronous converter does. The output of a nonsynchronous converter can float up, uncontrolled, without a preload.

Another advantage of a synchronous converter is tighter load regulation as shown by Figure 3. The main reason is that the forward voltage in a rectifier diode changes with load current while the voltage drop in a MOSFET remains consistent and low.

This circuit was designed primarily to provide 3.3V at 3.5A from an input of 37V to 54V. Nevertheless, converter operation is seamless over the full 36V to 72V input range (remove D1 if operated at 72V_{IN}). Operation of this circuit

is straightforward. MOSFET Q1 turns on and energy is stored in the transformer T1. Energy is then delivered to the output during the time MOSFET Q1 is off. MOSFET Q3 turns on whenever MOSFET Q1 turns off, providing output rectification. Secondary MOSFET Q3 is driven by transistor drivers Q12 and Q13. T2 inverts the LT1725 gate signal and drives the common bases of Q12 and Q13. R1, D6, Q9 and Q11 buffer the primary side gate signal and provide a small delay so that Q1 and Q3 are never on at the same time.

Complementing this converter is the LTC[®]4257-1, which provides complete signature and interface functions for a PD operating in an IEEE 802.3af PoE system.

Conclusion

To get the most out of the power available for a PoE supply, a converter needs to have synchronous rectification. The flyback topology offers the simplest solution and can operate synchronously with small incremental cost. The power consumed by the Q3 MOSFET in this design is roughly one tenth of that of a rectifying diode. The 1.4W of total converter dissipation is evenly distributed among switching MOSFETs, power transformer and controller IC, allowing the designer to compact board layout. The LT1725 greatly simplifies circuit design because of its patented feedback circuit which eliminates the need for an optocoupler and a secondary reference without sacrificing load regulation.

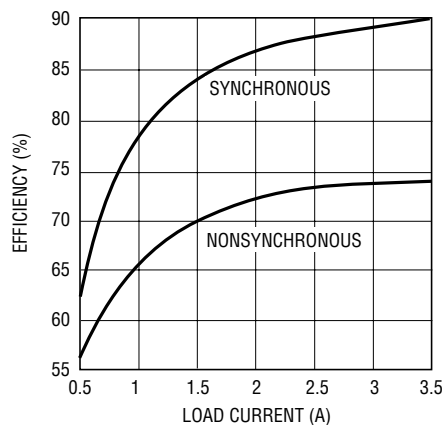

DN338 F01

Figure 2. Efficiency Comparison Between a Synchronous and Nonsynchronous Converter Using the LT1725

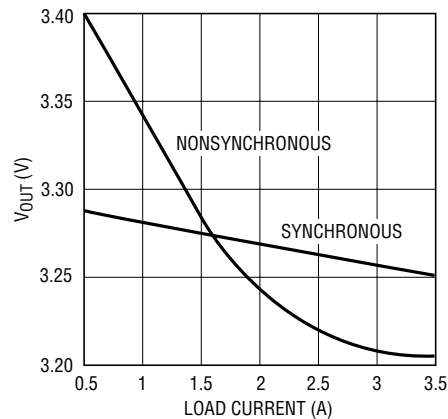

DN338 F03

Figure 3. Load Regulation Comparison Between a Synchronous and Nonsynchronous Converter Using the LT1725

Data Sheet Download

<http://www.linear.com>

For applications help,
call (408) 432-1900, Ext. 2593